

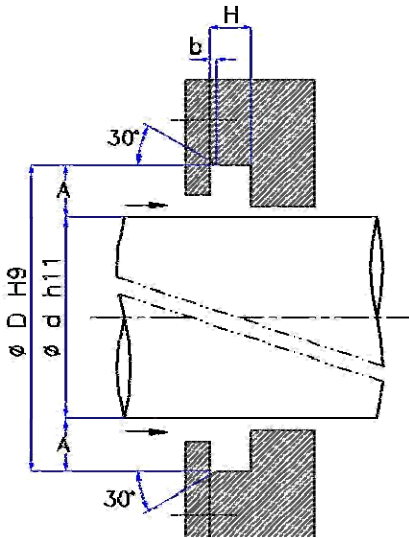

- Certificate 012 - ISO 9001:2000 -

CARCO S.p.a. Via Ugo Foscolo, 4 - 20060 Basiano (Milano) Italy,
Phone (+39) 02 95760331, Fax +39 02 95760333 AT 02701280923 www.carco.it info@carco.it

CARCOSEAL SELECTION



From : _____

Customer: _____

Date: __/__/__ Contact Person: _____

Quotation request No: _____

Drawing of sealing area enclosed : Yes No

Annual requirement : _____

Dimensions:

Shaft diameter (d) _____ [mm]

Housing diameter (D) _____ [mm]

Housing Width (H) _____ [mm]

Operating condition :

Shaft speed _____ [m/s] _____ [rpm]

Pressure Negligible Normal _____ [bar] Min. _____ [bar] Max _____ [bar]

Temperature Negligible Normal _____ [°C] Min. _____ [°C] Max _____ [°C]

Lubrication Dry Grease Oil Water Other : _____

Aim: Excluding dirt entrance Excluding lubricant exit.

Retaining plate : Yes No

Material selection :

NBR (S820) HNBR (HT720) VITON (Z420)

Model selection:

UN UN/SF SCA SCA/SF UN/LL UN/LA ATLMP TM AP APWT LDS

Others _____

Special requirements :

Split Endless No Carcoflon Others : _____

Problem description:

Application description:

Seal design :

Current seal _____ New development _____

Special configuration : Back to back

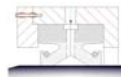

Tandem



Remarks :

