

CARCOSEAL AP/WT

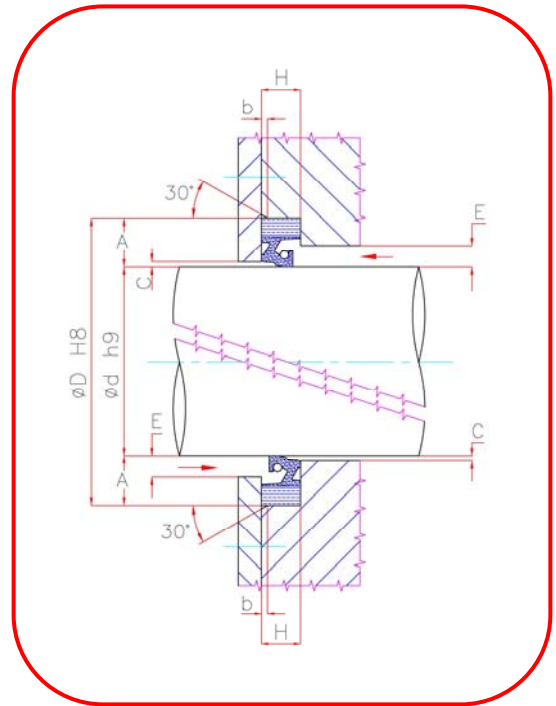

Carco seal AP / WT. The lip is designed so that the effect of pressure generates a favourable stabilizing torque which prevents the surface contact area between lip & shaft from increasing.



d (mm)	HxA (mm)	b (mm)	E (mm)	C (mm)	H (mm)	
<50	10 x 11	1,2	5	0,5	10	+ 0 -0,05
50+100	12,5 x 16	1,5	7	0,5	12,5	+ 0 -0,07
100 + 250	16 x 20	2,0	9	1	16	+ 0 -0,1
250 + 400	20 x 22	2,2	11	1	20	+ 0 -0,1
400 + 600	22 x 25	2,5	11	1	22	+ 0 -0,1
> 600	25 x 32	3,2	14	1,5	25	+ 0 -0,1

Standard section related to shaft diameters.

The ideal finish is obtained with plunge grinding. It's important that the shaft sealing area is free from machining marks, dents, burrs, scratches or other surfaces' defect.

Surface finish		
Surface roughness	Min	Max
Ra	0,2 μm	0,5 μm
Rt	1 μm	4 μm

Our sealing systems are mainly produced with rubberized fabric & elastomers. Today we mainly offer 3 standard materials.

MATERIAL		Temperature (°C)	Max Pressure (Bar)	Max Speed (m/s)
Code	Type			
S820	NBR	-40 ÷ 120	4	10
HT720	HNBR	-40 ÷ 170	5	15
Z420	VITON	-30 ÷ 200	6	15

Our three standard materials are designed to cope with these conditions .

All our products undergo our exclusive Carcoflon treatment which gives considerable reduction of the dry friction coefficient.

To facilitate the installation the shaft should have a chamfer with length "L" as function of its diameter "d" as indicated in graph below.

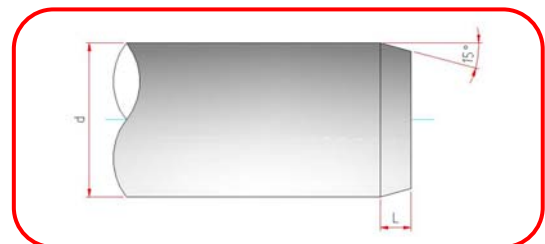

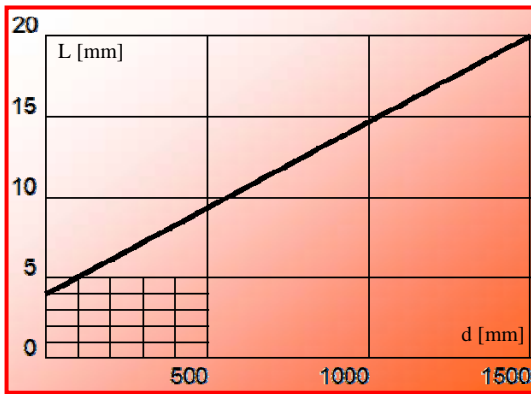

Eccentricity

Rotating seals under pressure Carcoseal /AP/WT, to be able to perform satisfactory, should not be subjected to any eccentricity.

KIT

With Carcoseal AP/WT, beside the standard single seal fitting, a multitude of different fittings are feasible.

Among them :

- Series of seals with spacers rings tandem;
- Series of seals with spacers rings back to back;
- A combination of both.

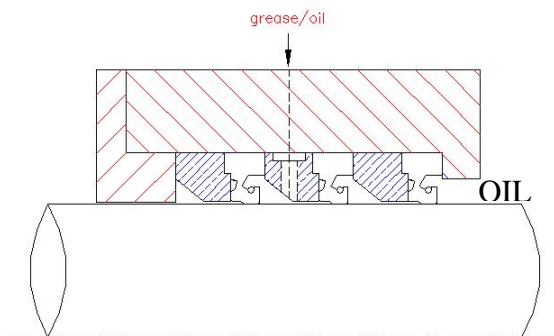

KIT toward Oil leakage

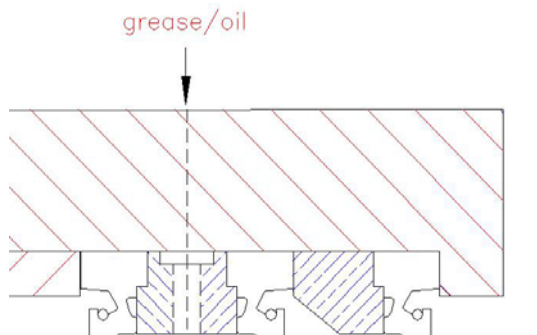

KIT Back to Back and Tandem

Please contact our technical dept for details.

CARCO S.r.l.
Via U. Foscolo, 4
20060 Basiano (MI)
☎ Tel +39.02.95760331
☎ Fax +39.02.95760333
<http://www.carco.it/>

CARCO GmbH
Borstelmannsweg 143
20537 Hamburg
☎ Tel: +49 (0)40 21985855
☎ Fax: +49 (0)40 21907180

E-Mail: sales@carco-germany.de
<http://www.carcoseal.com/>